

ALUMINIUM PROFILE WRAPPING MACHINE



APAM 7000DH

TECHNICAL DETAILS

WRAPPING MACHINE

WRAPPING

Designed to facilitate the packaging of profiles before shipment, this machine offers features that ensure high efficiency and ease of use. The drum motor has a power of 1.5 kW, with an adjustable speed range of 0-200 rpm, controlled by a digital potentiometer.

Additionally, the 0.37 kW drive motor operates within a speed range of 0-30 m/min, allowing the profile wrapping speed to be adjusted through digital displays on the operator panel.

The packaging process is carried out with two packaging reels on a drum supported by nine bearings. The drum operates stably and quietly, with a braking motor enabling quick and safe stops. The device can package profiles and groups up to a maximum size of 270x220 mm, and it is capable of wrapping round profiles up to a diameter of 300 mm.

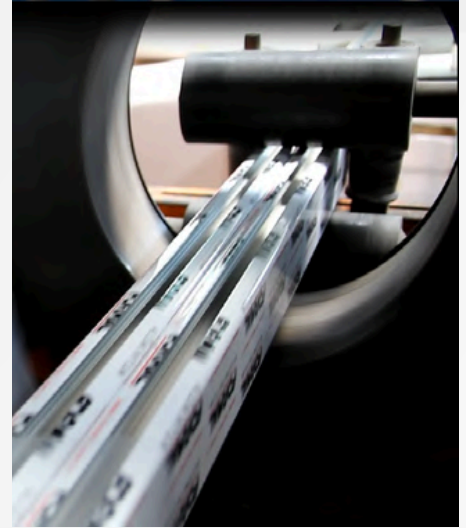
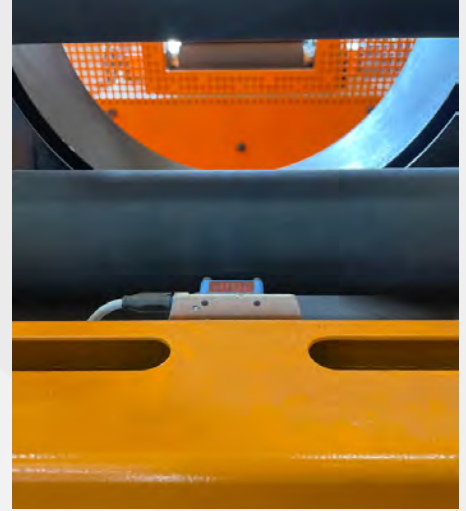

OUTFEED CONVEYOR

INFEED CONVEYOR

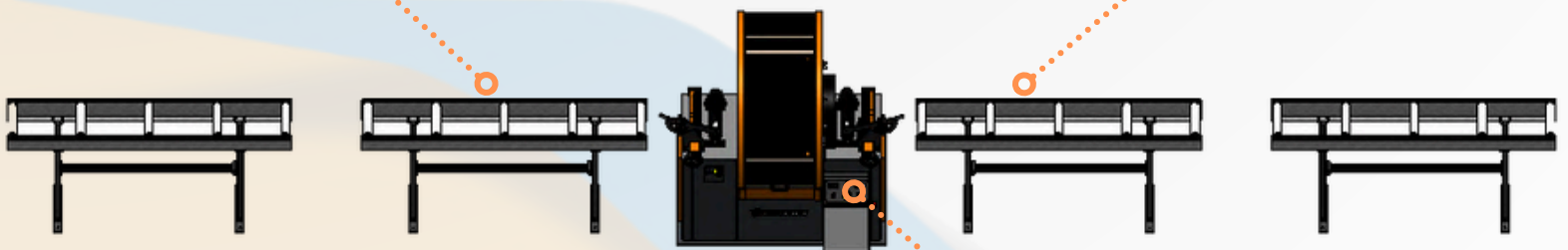

0-200 DRUM RPM
0-30 M/M FEED SPEED

WEIGHT & DIMENSIONS

WRAPPING MACHINE



Seri	Conveyor Dimension (Disassembled)			Machine Dimension			Power			Weight
	Widht	Lenght	Height	Widht	Lenght	Height	Volt	Phase	Total	
7000	395 mm	2.000 mm	850 mm	1.800 mm	1.350 mm	1.850 mm	400	3	1,87 KW	860 KG

PROFILE CAPACITY & BRUSH DIMENSIONS

WRAPPING MACHINE

Seri	Electric Motors		Packing Dimension & Type		Maks. Profile Capacity
	Drum	Drive	Dimension	Type	Standart
7000	1 x 1,5 kW 1500 d/d.	1 x 0,37 kW 1500 d/d.	İç: Ø75 Dış: Ø240 125 mm	Naylon - Kağıt	270 x 220 mm



Adjustable drum and feed speed via control panel



Coils designed for paper and nylon wrapping



Prevention of empty wrapping with a motorized brake



Inverter-controlled drum and drive motor



Safety switch cover



Profile feed control with sensor

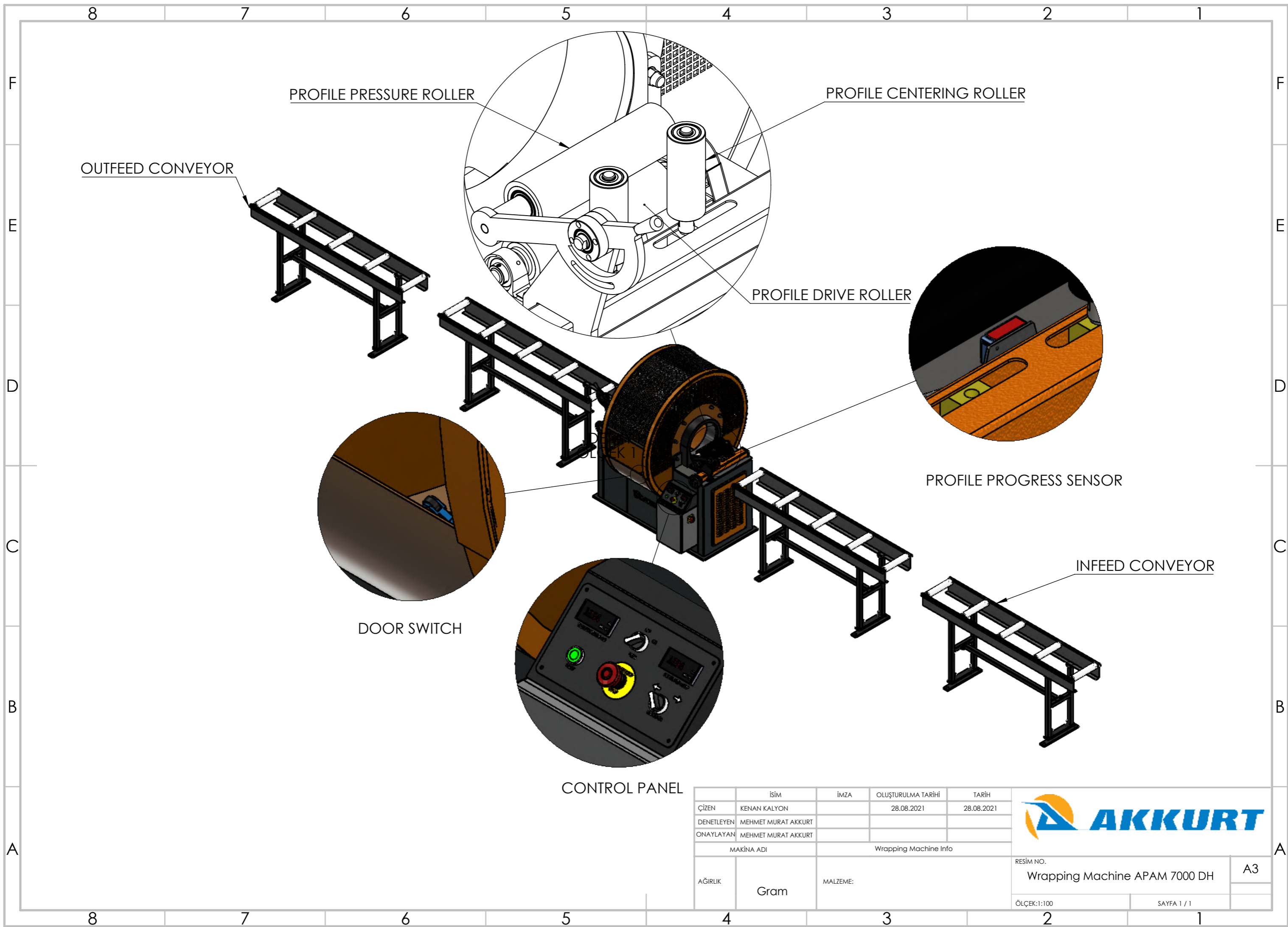

	İSİM	İMZA	OLUŞTURULMA TARİHİ	TARİH
ÇİZEN	KENAN KALYON		28.08.2021	28.08.2021
DENETLEYEN	MEHMET MURAT AKKURT			
ONAYLAYAN	MEHMET MURAT AKKURT			
MAKİNA ADI		Wrapping Machine Info		
AĞIRLIK	Gram	MALZEME:		

AKKURT

RESİM NO.
Wrapping Machine APAM 7000 DH

ÖLÇEK: 1:100

SAYFA 1 / 1

A3

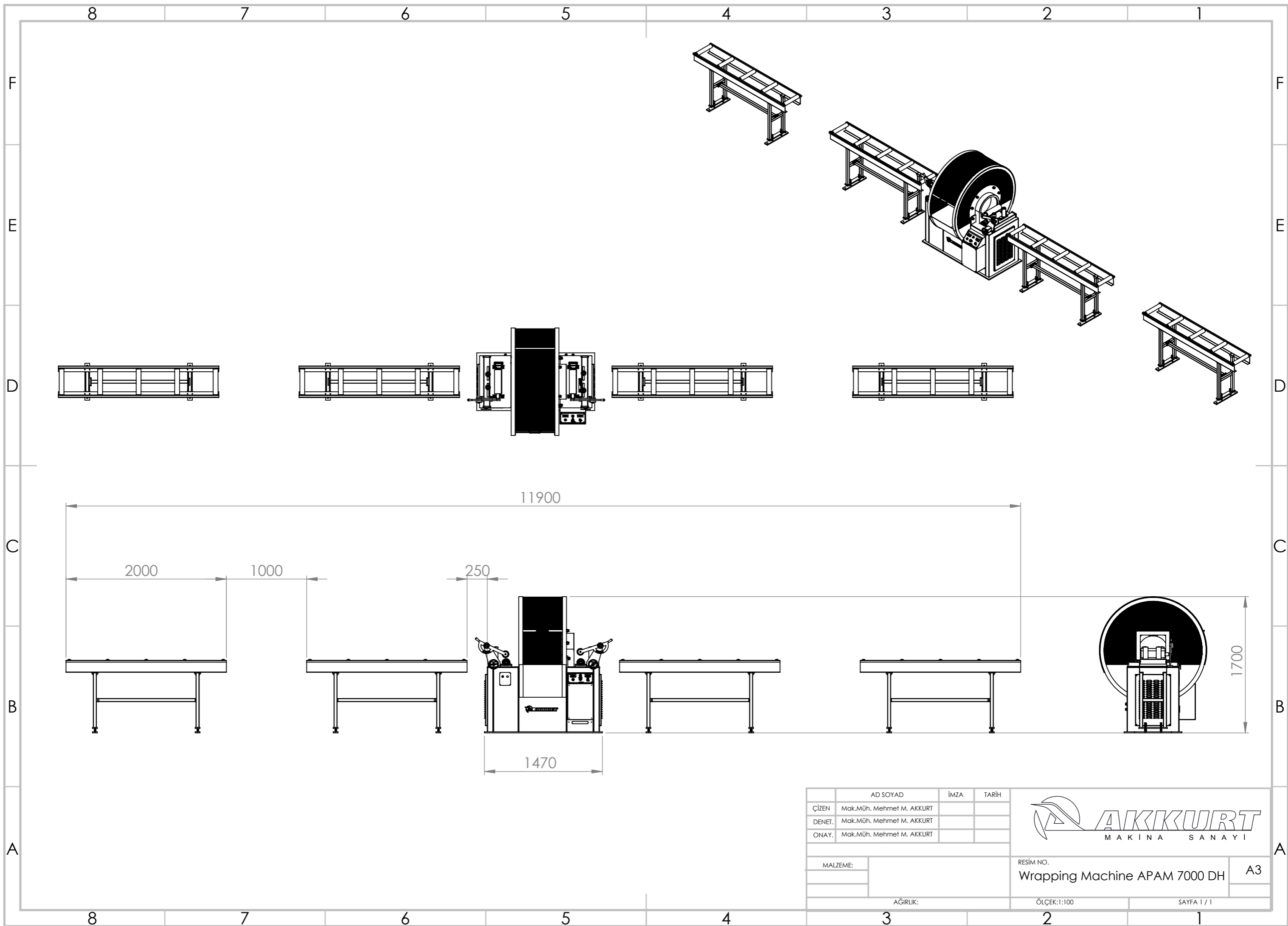

	AD SOYAD	İMZA	TARİH
ÇİZEN	Mak.Müh. Mehmet M. AKKURT		
DENET.	Mak.Müh. Mehmet M. AKKURT		
ONAY.	Mak.Müh. Mehmet M. AKKURT		
MALZEME:			



RESİM NO. A3
 Wrapping Machine APAM 7000 DH
 ÖLÇEK:1:100
 SAYFA 1 / 1

AĞIRLIK: